



**Power Flame Inc.**

AN ASTEC INC. COMPANY

# X4 & X4M

## Installation and Operation Manual



# FOR YOUR SAFETY

If you smell gas:

1. Open windows.
2. Do not touch electrical switches.
3. Extinguish any open flame.
4. Call your gas supplier immediately.

Do not store or use gasoline or other flammable liquids and vapors in the vicinity of this or any other appliance.

## WARNING

Improper installation, adjustment, alteration, service or maintenance can cause injury or property damage. Refer to this manual. For assistance or additional information consult a qualified installer, service agency or the gas supplier.

## NOTICE

Effective 4/1/94 Underwriters Laboratories require that all gas burners firing at inputs of 2,500 MBH and under be supplied with two gas safety valves or one gas valve with proof of closure (Valve seal over travel). The photos in this manual may not depict these specific components. ALL U.L. listed products shipped after 4/1/94 will comply with the U.L. requirements.

## IMPORTANT

**THE INSTALLATION OF A BURNER SHALL BE IN ACCORDANCE WITH THE REQUIREMENTS OF AUTHORITIES HAVING JURISDICTION.**

**THESE INSTRUCTIONS SHALL REMAIN WITH THE EQUIPMENT FOR SERVICING.**

**THESE INSTRUCTIONS SHALL BE POSTED AND MAINTAINED IN LEGIBLE CONDITION.**

**DO NOT TAMPER WITH THE UNIT OR CONTROLS, CALL YOUR SERVICE PERSON.**

**REGULAR MAINTENANCE SHALL BE PROVIDED TO THE UNIT BY SERVICE PERSONNEL AT LEAST ONCE A YEAR.**

## Table of Contents

1.	GENERAL INFORMATION .....	1
2.	CAPACITIES & SPECIFICATIONS .....	1
3.	ACCEPTANCE PROCEDURE .....	2
4.	INSTALLATION .....	2
5.	GAS PIPING .....	4
6.	WIRING .....	7
7.	START UP .....	7
8.	COMBUSTION ARRANGEMENT REQUIREMENTS.....	11
9.	SERVICE/MAINTENANCE SUGGESTIONS.....	12
10.	BURNER PARTS LIST X4 .....	13
11.	SEQUENCE OF OPERATION FOR X4M BURNER .....	16
12.	X4M HTD (High Turn Down).....	20
13.	OWNER OPERATING INSTRUCTIONS .....	22

## List of figures

Figure 1:	Mounting in Heat Exchanger .....	2
Figure 2:	Mounting in Boiler Base .....	3
Figure 3:	UL Gas Piping Train (X4) – See Figure 14, page 18, for X4M .....	5
Figure 4:	Location of Side Orifice .....	5
Figure 5:	Typical Wiring Diagram for S8680J with Proved Pilot Ignition.....	6
Figure 6:	Typical Wiring Diagram for S89F with Direct Spark Ignition.....	6
Figure 7:	Pilot/Gun Assembly – Flame Rod Type – Natural Gas/LP Gas.....	8
Figure 8:	Detail Pilot Assembly .....	8
Figure 9:	Detail Direct Spark Gun Assembly .....	10
Figure 10:	X4 general assembly and parts.....	14
Figure 11:	X4M general assembly and parts.....	14
Figure 12:	X4 specifications and dimensions .....	15
Figure 13:	Typical Wiring Diagram For X4M with LF-24 Actuator .....	17
Figure 14:	General Arrangement Diagram for X4M (AMCX-24).....	18
Figure 15:	Belimo LF24-SR-S Actuator .....	18
Figure 16:	Belimo AMCX-24 Actuator .....	19
Figure 17:	X4M Firing Rate vs Manifold Pressure.....	19

## List of tables

Table 1:	X4 Specifications.....	1
Table 2:	Combustion Chamber Recommended Dimensions.....	3
Table 3:	Gas Piping Pressure Drop Data .....	4
Table 4:	Equivalent length in feet for fittings.....	4
Table 5:	Natural/LP Gas Orifice Pressure Settings/Flow Rate .....	11
Table 6:	Firing rate and damper opening for X4M-HTD.....	20

## 1. GENERAL INFORMATION

- 1.1 The X4 burner is a new generation of gas power burner designed to fire natural gas and propane against a positive furnace pressure.
- 1.2 The burner is a self-contained unit comprised of a blower assembly, firing head, ignition system, combination gas valve, flame safeguard and control panel. It only requires connection of 115V electrical supply, minor gas train piping, connection to gas service, and operating controls.
- 1.3 All Power Flame burners are operationally fire tested at the factory.
- 1.4 Nomenclature:

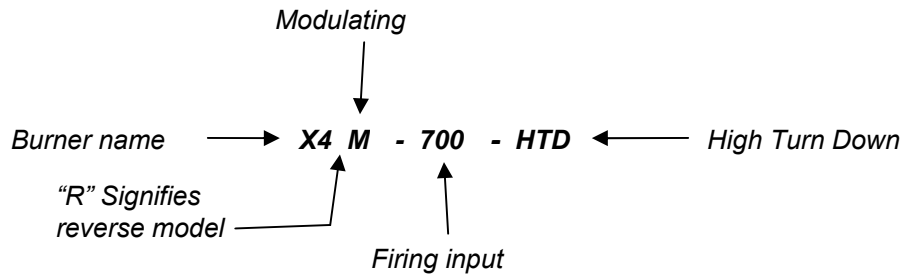

- 1.5 If additional clearance is required the following may be performed. Rotate the fan housing to the top, rotate gas valve to the vertical position, remove panel cover and rotate and reinstall.

## 2. CAPACITIES & SPECIFICATIONS

BURNER SPECIFICATIONS					
<b>Input Capacity (Btu/hr)</b>	X4(M)-400	150,000 - 400,000	<b>Fuel Type</b>	Natural or LP Gas	
	X4M-400HTD	35,000 - 425,000			
	X4-700	200,000 - 725,000	<b>Blast Tube Length</b>	9", 12"	
	X4M-700	90,000 - 725,000	<b>Voltage</b>	120V, 60 Hz	
	X4M-700HTD	65,000 - 725,000	<b>Amp Rating</b>	5.0 Amp	
<b>Gas Train Size</b>	X4-400	3/4"	<b>Motor</b>	1/4 Hp 3450 RPM	
	X4-700	1"	<b>Transformer</b>	40VA, 24 VAC	
	X4M-400	3/4"	<b>Gas Valve</b>	X4(M)-400 w/direct spark	Honeywell VR8305M
	X4M-700	1"		X4(M)-400 w/proved pilot	Honeywell VR8304M
<b>Blower Wheel Size</b>	X4-400	6-1/4" x 2-3/4"	X4(M)-700 w/proved pilot	Robert Shaw 7000DERHC-S7A	
	X4-700	7" x 3"	<b>Primary Control</b>	direct spark	Honeywell S89F
	X4M-400	6-1/4" x 3-3/4"		proved pilot	Honeywell S8680J
	X4M-700	7" x 3"	<b>Max Inlet Pressure to Main Shut-off Cock</b>	14" W.C.	

### 3. ACCEPTANCE PROCEDURE

- 3.1 Open the box and carefully remove the top cardboard packaging. Lift the burner from the box and ensure all shipped loose items are removed before discarding the box. Check all parts received against your computer generated Bill of Material that is enclosed in the owner's information envelope.
- 3.2 **Warranty:** The Owners Information envelope packed with the burner contains a Warranty Registration Card. The Warranty Registration Card is also a request form for a Spare Parts List. An on-hand supply of spare parts is highly recommended in case of emergency shutdown. We request that you complete and return the card to Power Flame in the enclosed self-addressed envelope as soon as possible.

### 4. INSTALLATION

- 4.1 Prior to Installation, carefully study these instructions, all charts, drawings and diagrams shipped with the burner. Installation must be in accordance with all local and national codes including CAN1-B149.1 or B149.2 and Canadian electrical codes for Canadian installations.
- 4.1.1 - For Canadian Installations: Identify the main electrical power disconnect and manual shut-off valve on the gas supply line to the burner.
- 4.2 If the burner is to be mounted in an existing boiler or furnace, ensure that all fireside surfaces are clean and in good condition. All doors, cleanouts, cracks or other openings allowing excess air into the combustion chamber should be tightly sealed, whether the burner is to be fired under positive or negative combustion chamber conditions.
- 4.2.1 - The equipment shall be installed in accordance with the Provincial Installation Requirements, or in their absence, the CGA B149.1 and B149.2 Installation codes shall prevail.
- 4.3 The burner can be mounted through a heat exchanger end wall or in the base of the boiler – **see Figures 1 and 2**. The opening for the burner blast tube should not be less than 4 ¼ inches in diameter to allow easy removal of the burner. The gap between the burner opening and the blast tube should be sealed with non-asbestos, high temperature rope or Ka-O-Wool. Where a new or replacement combustion chamber lining is to be used, the chamber is to be built using 2300 degree F insulating firebrick or ceramic fiber blanket.

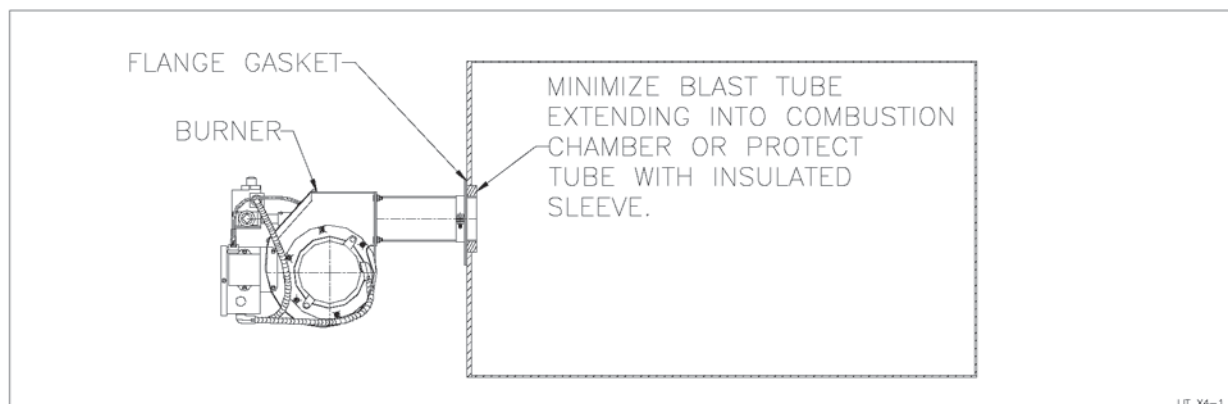
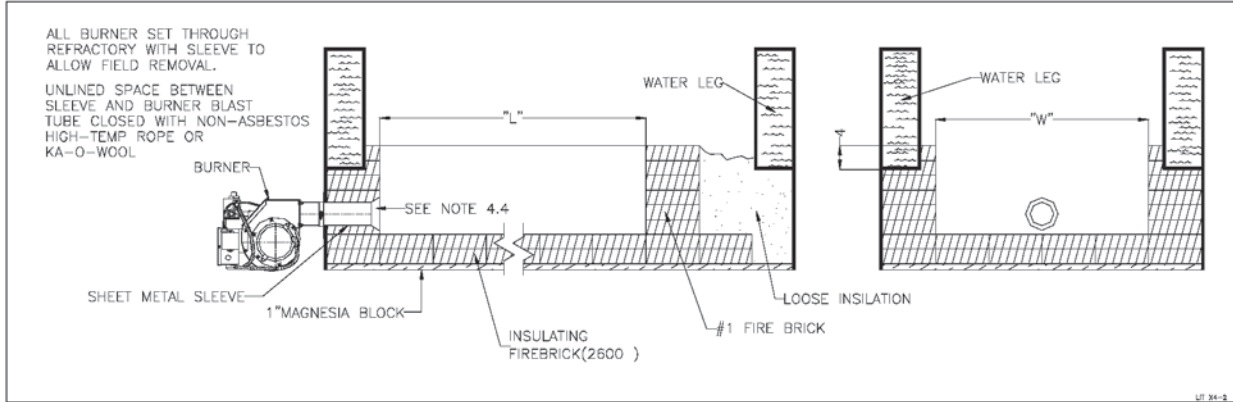

Figure 1: Mounting in Heat Exchanger



**Figure 2: Mounting in Boiler Base**

4.4 Combustion chamber sizing:

<b>Gas Input MBTU/HR</b>	<b>Width Inches</b>	<b>Length Inches</b>
250	13	17
450	15	20
600	16	23
700	17	25
850	18	26

**Table 2: Combustion Chamber Recommended Dimensions**

4.5 Whichever method of mounting is chosen, the burner blast tube must be recessed into the front wall surface from 0" to 1/2".



**Serious Damage To The Burner May Result If The Blast Tube Is Extended Into The Combustion Chamber.**

4.6 Secure the burner to the heat exchanger or boiler using the burner-mounting flange. The burner-mounting flange must be secured to the blast tube at the selected location for proper insertion into the end or front wall of the fired unit. A tight seal between the mounting flange and the front plate should be accomplished using the factory-furnished gasket or a ceramic or other non-asbestos fiber rope.

## 5. GAS PIPING

- 5.1 Contact your local gas service company to ensure that adequate gas service is available and to review applicable installation codes for your area. All gas piping installations must be in accordance with NFPA 54, National Fuel Gas Code, Definitions and General Field Recommendations, CGA 3.0, Canadian Natural Gas Installation Code CAN/CGA B149.1 or Propane Installation Code, CGA B 149.2. This product must be installed only by a Licensed Plumber or Gasfitter when installed in the Commonwealth of Massachusetts.
- 5.2 Size the main gas line in accordance with **Table 3**. The figures shown are for straight lengths of pipe at 0.2" w.c. pressure drop, which is considered normal for low-pressure systems. Note that fittings such as elbows and tees will add to the pipe pressure drop (**Table 4**).

Pipe Size In Inches	EQUIVALENT LENGTH OF STRAIGHT PIPE IN FEET								
	20	30	40	50	60	80	100	150	200
	CFH GAS WITH 0.2" PRESSURE DROP								
3/4"	152	120	105	93	84	73	66	54	45
1"	300	250	210	190	180	150	135	110	75
1-1/4"	520	425	360	325	300	260	230	190	165
1-1/2"	800	690	560	500	480	410	370	300	260
2"	1700	1400	1200	1100	1000	850	750	600	540
2-1/2"	3000	2500	2100	1900	1800	1550	1375	1100	950

**Table 3: Gas Piping Pressure Drop Data**

Nominal Pipe Size In Inches	EQUIVALENT LENGTHS OF STANDARD PIPE IN FEET FOR LISTED FITTINGS						
	3/4	1	1-1/2	1-1/2	2	2-1/2	
Fitting Type	Std. Tee	2.4	5.5	7.5	9	12	13.5
	Std. Elbow	4.4	2.7	3.7	4.5	5.5	6.1

**Table 4: Equivalent length in feet for fittings**

- 5.3 **Refer to Figure 3** for details of gas piping. (Also refer to any additional piping diagrams supplied for this specific unit.)
- 5.4 Mount leakage test and main gas cocks, main automatic gas valve or combination gas valve/pressure regulator, and auxiliary valves (if required and not factory mounted) per piping diagram or **Figure 3**.
- 5.5 Install pressure regulator (not used with combination gas valve/pressure regulator) directly upstream of main automatic gas valve(s) and fit drip leg and main gas cock upstream of regulator or automatic valve(s).
- 5.6 The pilot line should be piped into the upstream tapped nipple to minimize pilot line piping length. An optional location is in a tapping located on the main shut-off cock. **Refer to Figure 3**. For ease of servicing, we recommend the use of a union immediately upstream of the main gas pressure regulator or combination gas valve/pressure regulator.
- 5.7 Install vent lines from main gas regulator (if used) and diaphragm gas valve where applicable. Vent lines should be run to the outside of the building, terminating clear of windows or fresh air intakes. Outside termination of vent should have a screen to prevent insects from building nests in vent pipe. The vent should terminate in a manner which will preclude the possibility of water, dirt or other foreign matter from entering the line.

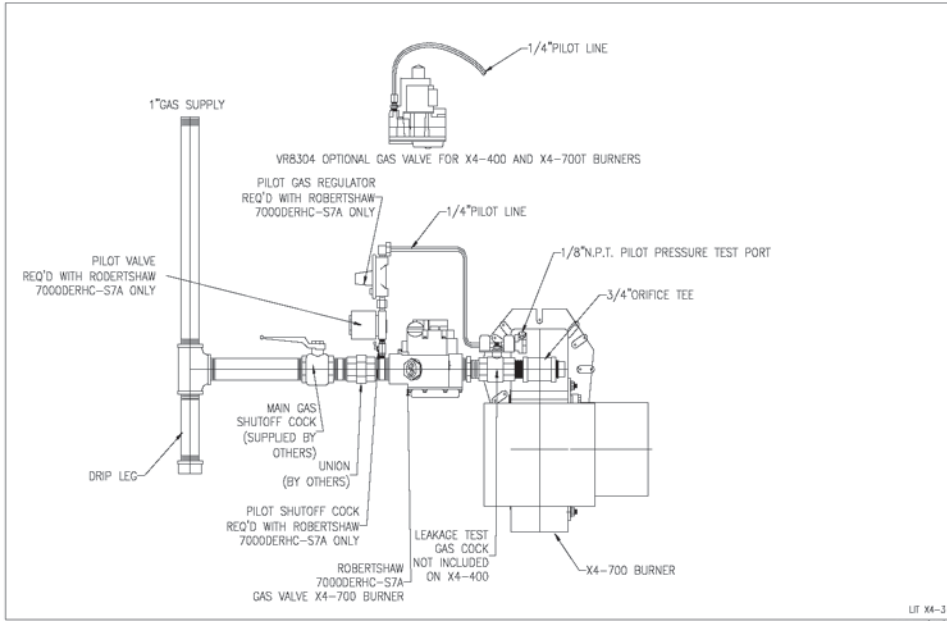

**Figure 3: UL Gas Piping Train (X4)**

- 5.8 Test gas lines for leaks using a soap solution. Your local gas service company may wish to execute or witness this test. **CAUTION** – gas pressure above 14" w.c. may damage the standard diaphragm gas shut-off valve. Do not exceed this value when pressure testing lines unless you cap off line upstream of main gas cock and pilot take-off.
- 5.9 Check that side orifice size is correct according to burner specification sheet (**See Figure 4**). To gain access to orifice, remove Plug A and withdraw spring and orifice. When reinserting or replacing the orifice, ensure that it seats properly inside the tee and reinstall plug.

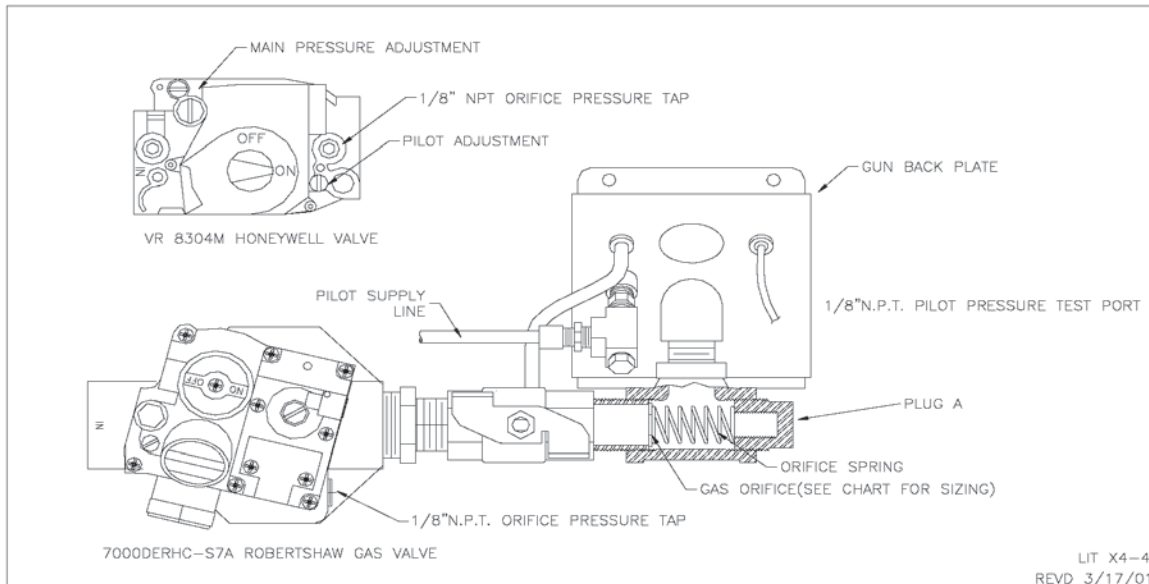

**Figure 4: Location of Side Orifice**



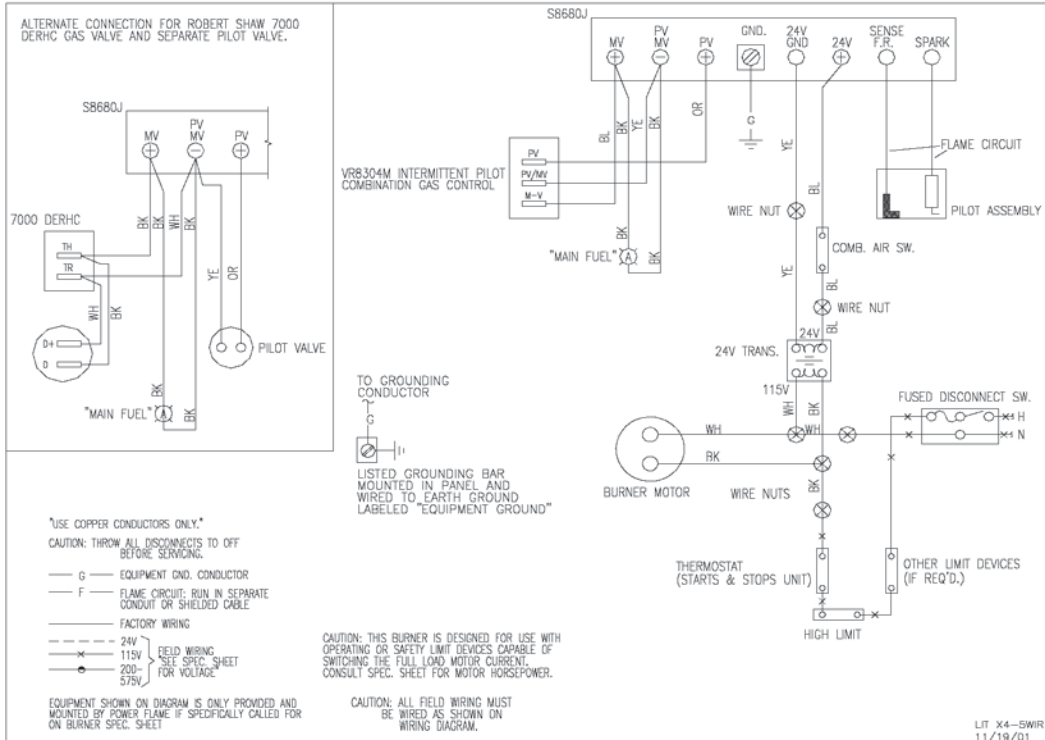

Figure 5: Typical Wiring Diagram for S8680J with Proved Pilot Ignition

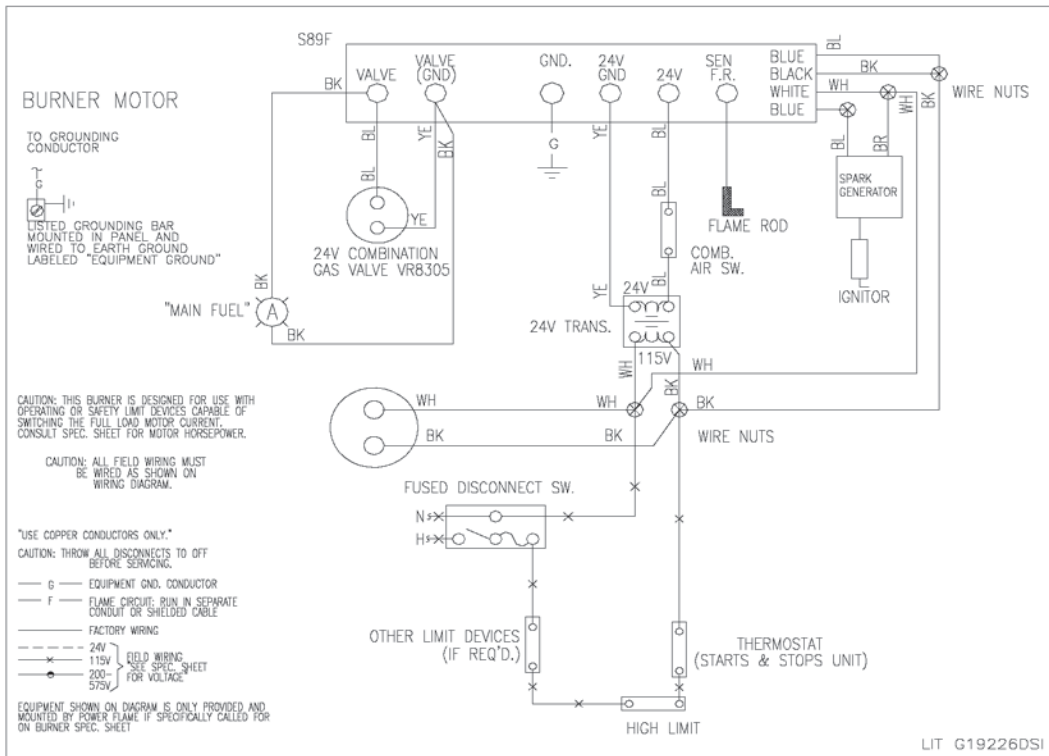

Figure 6: Typical Wiring Diagram for S89F with Direct Spark Ignition

## 6. WIRING

- 6.1 Refer to wiring diagram shipped with burner and typical wiring diagrams **Figures 5 and 6**. The two power leads (black and white) are located inside the burner panel.
- 6.2 Electrical installation must be made in accordance with the NEC NFPA 70 or Canadian Electrical Code, Part 1 and applicable local codes. If this burner is part of a boiler or furnace package system, check wiring diagram as supplied by the boiler or furnace manufacturer.

## 7. START UP

- 7.1 Before attempting a burner start up, thoroughly study and familiarize yourself with the exact sequence of operation and all other details on the specific Primary Safety Control System being used. This information will be found in bulletins supplied with the burner, as well as technical bulletins covering other components. All of these materials should be used as reference in burner start up and service.
- 7.2 Check boiler water level (if applicable).
- 7.3 Lay out combustion test equipment (**see Section 8.3**).
- 7.4 Attach gas pressure gauge or manometer to upstream side of main gas cock (0-35" w.c.) and to orifice pressure tap (0-10" w.c.) as well as to pilot gas pressure test tee tapping (0-10" w.c.).
- 7.5 Check the voltage at the disconnect switch to make certain that it matches that indicated on the burner label.
- 7.6 Ensure that all dampers in the flue or stack are fully open.
- 7.7 Install stack thermometer and Flue Gas Analyzer sample line into breeching and connect the draft gauge to combustion chamber test point.
- 7.8 Connect a microammeter to the Primary Safety Control as directed in the PSG control manufacturer's instruction bulletin to determine flame detection system values. The meter is normally connected in series with the (SENSE) terminal on the S8600 or S89F series control.
- 7.9 With the main and leak test cocks and pilot cock in OFF position, turn on the gas cock at meter. Check to make certain that pressure upstream of main and pilot cocks does not exceed 14" w.c. (1/2 PSIG) – unless special valve train components suitably rated have been furnished (**Refer to Burner Specification Sheet**). If pressure is acceptable, proceed to next step.
- 7.10 **Pilot Ignition:** Next check the operation of the gas pilot system. **This is a very important part of the start up procedure.**
  - 7.10.1 Before attempting burner start up, make certain that you are familiar with the operation of the Primary Safety Control and other components being used on this specific application. **Refer to Fig. 7 and 8.**

7.10.2 To prepare the pilot for proper operation, it is essential that appropriate adjustments be made to the burner air inlet damper and the pilot gas pressure. **See Table 5** for the approximate air damper setting at the various firing rates. Typical pilot test pressures are 3" to 4" w.c. for natural and propane gas. Normally, lower pressures are required for air damper openings of 50% or less.

7.10.3 Frequently, the cause for pilot problems relate to gas pressures that are too high and/or air dampers that are closed too far. Both conditions can cause a fuel rich mixture in the pilot chamber which can substantially delay or totally prevent pilot ignition.

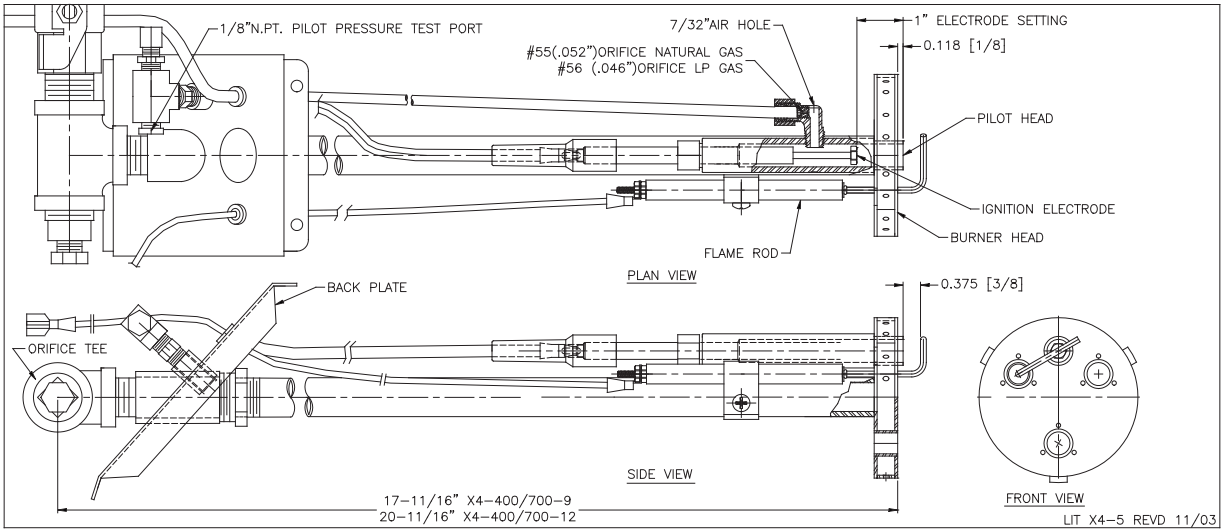

**Figure 7: Pilot/Gun Assembly – Flame Rod Type – Natural Gas/LP Gas**

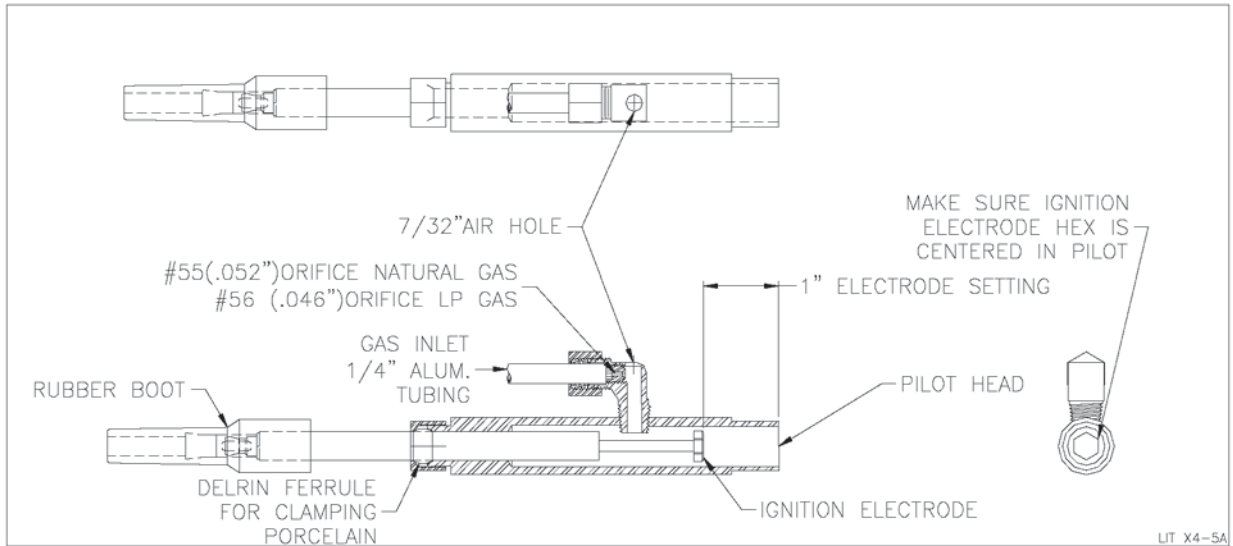

**Figure 8: Detail Pilot Assembly**

- 7.11 With the leak gas cock closed and pilot gas cock opened (if provided); turn the burner switch ON. The blower motor will purge the heat exchanger of **any accumulated combustibles**. At the end of the purge cycle, the pilot solenoid valve will energize and spark will be initiated. The pilot will attempt to light for 15 seconds. Adjust the pilot pressure at this time. If the pilot fails to light, power must be removed from the control for 60 seconds to allow it to reset. **Note**: If the leak test cock is not provided, remove the main gas valve wire (MV) from the control to prevent the main valve from energizing during the pilot adjustment period.
- 7.12 **Pilot Adjustment and Main Flame Light Off Procedure**
- Select and install the main orifice that corresponds to the desired firing rate.
- 7.12.1 Note: X4 Burners light off at the high fire position. Set the air flow (**see Table 5**) and pilot gas pressure in order to provide instant pilot ignition, good flame stability and a strong/steady signal reading. This can be accomplished as follows: Start with the pilot pressure at the minimum adjustment on the regulator. When the pilot valve energizes begin increasing the pilot pressure. Note the pressure where a signal is obtained or the main valve energizes. This will be the minimum pilot pressure. Acceptable pilot and/or main flame current reading is 1 – 5 microamp.
- 7.12.2 Raise the pilot gas pressure to the point where the signal and/or main valve drops out noting this pressure. Reduce the pressure slightly and recycle the burner for an attempt to relight the pilot at this pressure. If relight occurs this is the upper limit of the pilot pressure. Now set the pilot pressure between the minimum and maximum pressure. This range is typically 1" w.c..
- 7.12.3 After attaining the proper pilot flame signal values, cycle the pilot off and on several times in order to ensure reliability (with the gas leak test cock still closed). **Turn Burner Switch Off.**
- 7.12.4 Having established pilot reliability, open gas leak test cock.
- 7.12.5 After burner has completed pre-purge and established a good pilot flame signal reading, the main automatic fuel valve will be energized. The main flame should light immediately. If light off does not occur, it is possible that air will need to be purged from the main gas line. Adjust main gas pressure regulator (if used) or combination valve regulator to obtain the desired firing rate pressure.
- 7.12.6 Adjust burner as necessary to provide smooth ignition of main flame. If pilot flame signal drops significantly when main fuel valve opens, increase pilot gas pressure slightly to obtain a reasonably stable flame signal value.
- 7.12.7 **See Section 8** and **Table 5** for firing rate information. Make certain that the airflow setting provides the correct CO<sub>2</sub> or O<sub>2</sub> levels and other combustion values at the proper firing input rates.
- 7.12.8 Generally accepted values for natural gas are 8½ to 10% CO<sub>2</sub> or 5½ to 3% O<sub>2</sub>. Equivalent CO<sub>2</sub> readings on propane gas are 10 to 11½% CO<sub>2</sub> or 5½ to 3½% O<sub>2</sub>. It is important that the CO (carbon monoxide) level is checked and held at 0% or minimum (typically under 100 ppm or 0.01%). Check with local utility and any other authorities having jurisdiction before making final burner adjustments.
- 7.13 **Direct Spark Ignition** (S89F control)
- 7.13.1 Before attempting burner start up, make certain that you are familiar with the operation of the Primary Safety Control and other components being used on this specific application. **Refer to Figure 9** to verify the correct position of the ignition electrode placement since shipment may have altered the placement.

- 7.13.2 Set the burner's combustion air inlet damper to the approximate setting as shown in this manual for the desired firing rate (**Table 5**). Also, verify that the correct main orifice is installed in the main orifice tee.
- 7.13.3 Open the main manual gas valve and turn the combination gas valve to ON. Turn the burner power on. The blower motor will purge the heat exchanger of any accumulated combustibles. At the end of the purge cycle, typically 35 seconds, the combination valve will be energized and a spark will be initiated. The trial for ignition will be approximately three seconds.
- 7.13.4 Complete setup in accordance with **item 7.12.7 and 7.12.8 above**.
- 7.13.5 If ignition failure occurs, the main power must be switched off for at least one minute to allow the control to reset. Refer to the Service/Maintenance section for further information on Direct Spark Ignition.

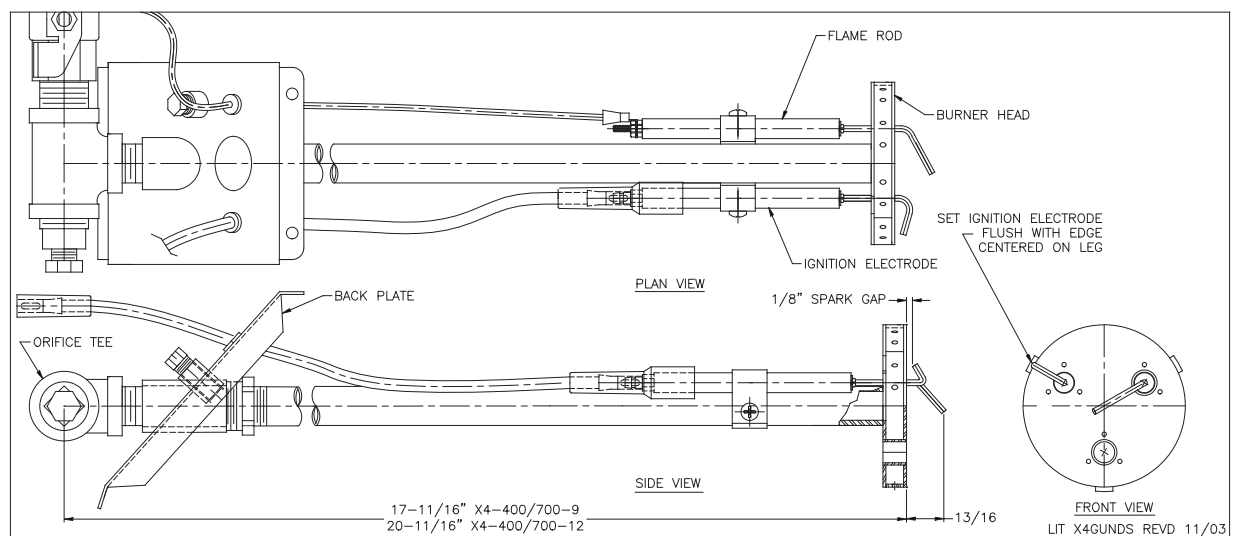

**Figure 9: Detail Direct Spark Gun Assembly**

- 7.14 Conduct all applicable test procedures shown in control manufacturer's bulletins included with burners. Set and check operation of low and high gas pressure switches (if applicable), all burner and heat exchanger controls, and operating devices. Check blower airflow switch by first closing main gas cock and disconnecting motor lead wire. A properly adjusted air switch should open within 3 to 4 seconds when the power is removed from the motor.
- 7.15 Clean up area around the burner and instruct owner and/or operator.
- 7.16 **Post Operating Instructions card (inside back cover)** close to the burner in clearly visible position.

## 8. COMBUSTION ARRANGEMENT REQUIREMENTS

- 8.1 The X4 burner has been designed to fire with high combustion efficiency into combustion chambers with positive, balanced or negative pressures using natural or LP gas only.
- 8.2 Caution: In order to fire efficiently, the burner requires an adequate supply of combustion air. Ventilation to any enclosed area should be provided on the basis of ½ square inch of opening for each 1000 BTU/HR input. This excludes the requirement for any other fired equipment in the area. The enclosed area should not become excessively hot and under no circumstances should be under a negative pressure.
- 8.3 The burner should be initially set up and serviced at regular intervals (preferably at the beginning of and mid-way through high use periods) by a trained serviceman using the proper test instruments. Failure to maintain the correct burner settings may result in inefficient gas consumption, premature wear of burner components or explosion hazard.
- 8.4 Approximate gas flows and pressures are shown in **Table 5** for natural gas and LP gas. Actual firing rates should be verified by clocking the gas meter and applying the appropriate correction factor.

X4-400								
Main Orifice Diameter/I.D.#	MBH Natural Gas 1000 BTU/CF			MBH LP Gas 2500 BTU/CF			Approx. Damper Position	
	2" w.c.	3" w.c.	4" w.c.	2" w.c.	3" w.c.	4" w.c.	MBH	Indicator #
0.203 / 1				133	180	198	150	1
0.234 / 2				158	196	227	200	2
0.265 / 3	150	183	210	213	250	287	300	3
0.281 / 4	175	215	248	219	264	292	400	4
0.343 / 5	200	245	280	298	351	389		
0.406 / 6	225	274	316	370	431		Note: Pilot pressure is different at each damper position and must be set at each position.	
0.468 / 7	275	338	390	410				
0.500 / 8	295	360	415					
None	400							

X4-700								
Main Orifice Diameter/I.D.#	MBH Natural Gas 1000 BTU/CF			MBH LP Gas 2500 BTU/CF			Approx. Damper Position	
	2" w.c.	3" w.c.	4" w.c.	2" w.c.	3" w.c.	4" w.c.	MBH	Indicator #
0.203 / 1					174	201	200	1
0.234 / 2				162	198	239	300	1 3/4
0.265 / 3	120	148	171	194	227	272	400	2
0.281 / 4	131	163	189	201	250	285	500	3
0.343 / 5	186	230	269	273	335	387	600	4
0.406 / 6	246	302	394	383	470	541	700	6
0.468 / 7	306	372	433	472	578	667	725	9
0.500 / 8	326	394	454	497	609	725	Note: Pilot pressure is different At each damper position and Must be set at each position.	
None	451	563	652					
	725 @ 4.8" w.c.							

**Table 5: Natural/LP Gas Orifice Pressure Settings/Flow Rate. NOTE: Pressure taken at Combination Valve Pressure Tap Upstream of Orifice**

- 8.5 The correct test instruments are:
- 1) O<sub>2</sub> analyzer (electronic or Fyrite absorption system)
  - 2) CO indicator (Monoxor or similar)
  - 3) Stack thermometer
  - 4) Draft gauge or inclined manometer
  - 5) U-tube manometer or calibrated 0-10" and 0-35" w.c. pressure gauge
  - 6) Combination volt/ammeter
  - 7) D.C. Micro-Ammeter

## 9. SERVICE/MAINTENANCE SUGGESTIONS

- 9.1 Burner fails to start:
- 1) Bad fuse or switch open on in-coming power source, or motor overload out.
  - 2) Control circuit has an open control such as operating, limit or low water cut-off.
  - 3) Push the reset button on the motor or open the power circuit to the primary safety control.
  - 4) Loose or faulty wiring. Tighten all terminal screws. Check wiring, against wiring diagram furnished with burner.
- 9.2 Burner motor runs, but pilot does not light:
- 1) Be sure gas is turned on at meter and pilot cock is open.
  - 2) Place hand on pilot valve to "feel" it open. Check gauge at tee in pilot line for gas pressure and prompt opening of pilot valve.
  - 3) Check visually or by sound for spark arcing.
  - 4) **Refer to section 7.10** on pilot checking procedures.
  - 5) Check air switch and be sure its circuit closes during start.
- 9.3 Burner motor runs, pilot lights, but main gas valve does not open:
- 1) Check flame signal. If signal is low, adjust pilot gas pressure and air damper settings for improved readings.
  - 2) Check gas valve circuit.
  - 3) Shut-off cock or test cock not open.
  - 4) Defective main valve.
- 9.4 Occasional lockouts for no apparent reason:
- 1) Re-check micro-amp readings. If insufficient, check gas pressure and air damper setting. Check electrode setting. If flame signal is low, flame rod may have to be re-positioned.
  - 2) Check ignition cable and electrode porcelain for damage or breaks, which could cause short.
  - 3) Check for loose or broken wires.
- 9.5 Burner will not start, even though burner had never failed before or had been running on normal cycling without failure:
- 1) Operating Control circuit open.
  - 2) Defective control or loose wiring.
  - 3) Limit circuit open.
- 9.6 The burner must be periodically inspected to insure safety and performance. All maintenance must be performed with the main electrical power off and the main gas shutoff valve off:
- 1) Inspect blower inlet screen and clean any buildup of lint.
  - 2) Inspect blower wheel blades and clean any buildup of dirt.
  - 3) Inspect ignition electrodes and wiring for any cracks that may cause shorting.
  - 4) Oil the blower motor at the manufacturer's recommended intervals.

- 5) Verify that the pilot and or direct spark electrodes are still within specifications (**set per drawing 7, 8 and 9 in this manual**).
  - 6) Verify the proper operation of the Primary Safety Control, airflow switch, and operating controls.
  - 7) Check safety gas shutoff valves for gas tightness.
- 9.7 In the event of extended shutdown, the main power should be turned off and the main manual gas shutoff valve should be closed.



**EMERGENCY SHUTDOWN: Should over-heating occur, (1) shut off the manual gas valve to the appliance, (2) do not shut off the control switch to the feed water pump or blower.**

- 9.8 An additional source of information relative to trouble shooting can be found in the Flame Safeguard Control Manual supplied with the burner.

## 10. BURNER PARTS LIST X4

1	Burner Housing	24	Pilot Tubing
2	Inlet Ring	25	Pilot Assembly
3	Blast tube (6", 9", 12")	26	Ignition Electrode
4	Gun Assembly	27	Flame Rod
5	Flange Gasket	28	Back Plate
6	Mounting Flange	29	Inner Damper
7	Blower Wheel	30	Middle Damper
8	Motor Plate	31	Outer Damper
9	Blower Motor	32	Air Sensing Tube
10	Air Switch	33	Orifice Kit
11	24 Volt Transformer	34	Direct Spark Transformer
12	Panel & Door	35	Gas Piping Support Bracket
13	Flame Monitor	36	Damper Axle
14	Grounding Lug	37	Relay
15	Nipple Tapped	38	5/16" Ball Joint Swivel
16	Gun Head	39	Mod Motor
17	Side Orifice tee	40	Butterfly Valve
18	Side Orifice Spring	41	5/16" Linkage Rod
19	Pilot Regulator	42	Light
20	Pilot Solenoid Valve	43	Axle Bushing
21	Combination Gas Valve	44	1/2" Damper Arm
22	Main Gas Cock	45	Pie DPR Retainer Washers
23	Pilot Gas Cock		



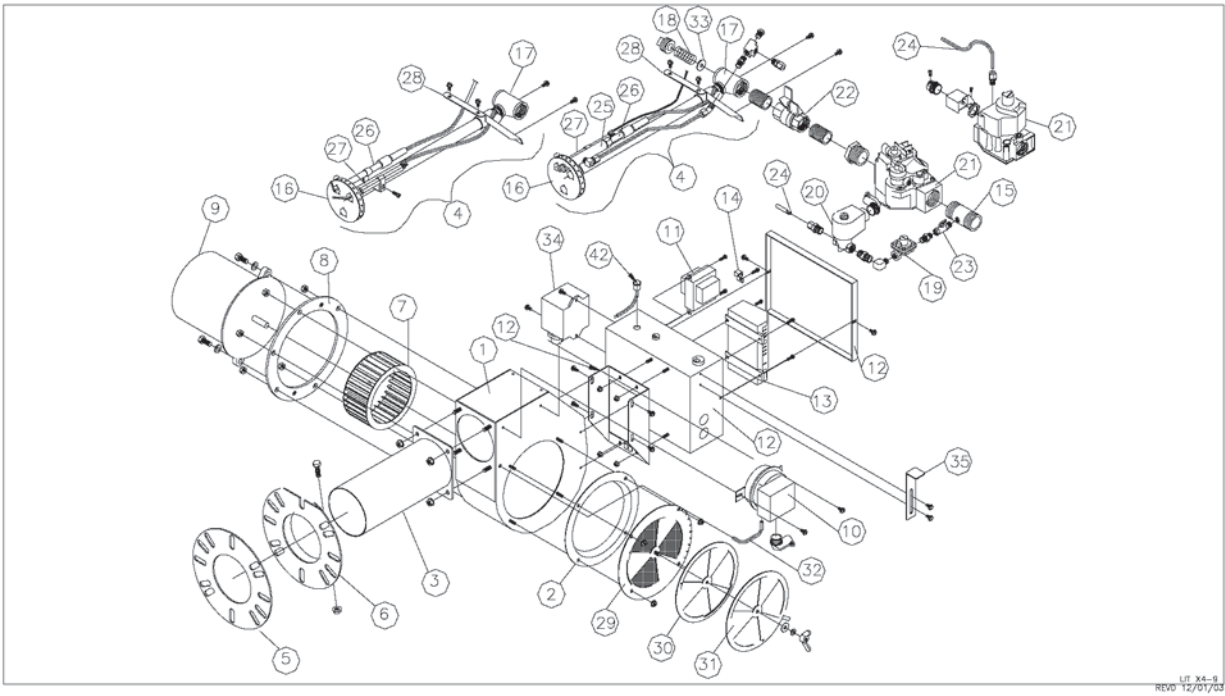

Figure 10: X4 general assembly and parts

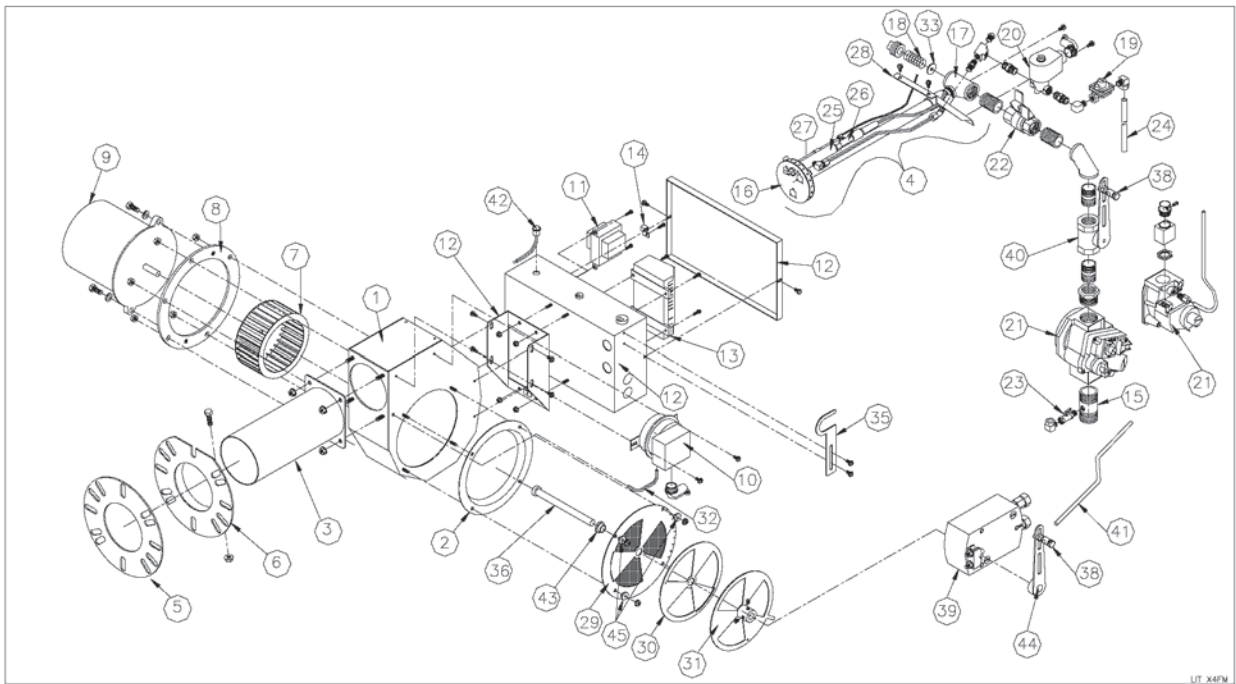

Figure 11: X4M general assembly and parts

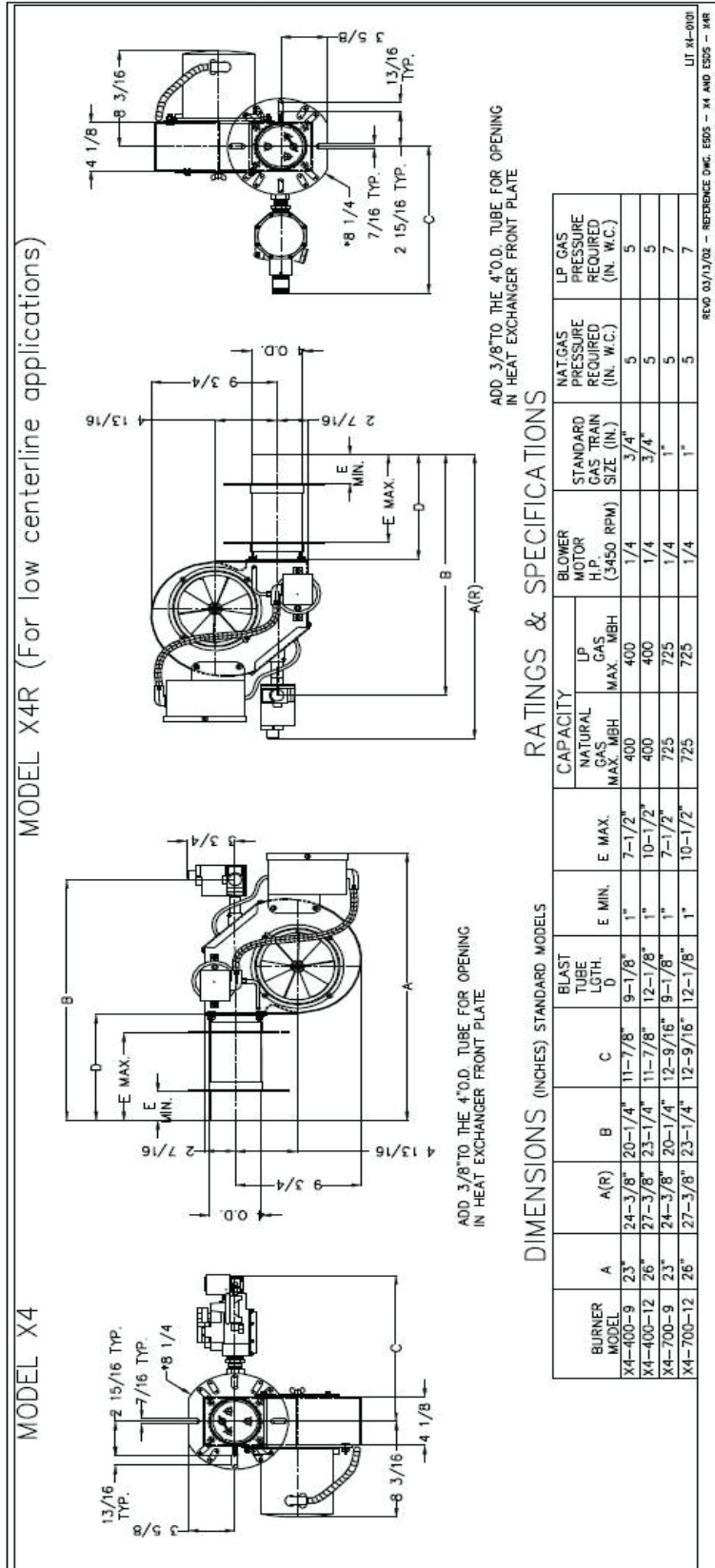

Figure 12: X4 specifications and dimensions

## 11. SEQUENCE OF OPERATION FOR X4M BURNER

### LF-24 BELIMO ACTUATOR

- 11.1 Refer to typical wiring diagram for X4M burner (**Figure 13**). Upon a call for heat, the blower motor starts, closing the combustion air switch. Power is supplied to the 24-vac transformer. Initially, power to the actuator is held out through one set of normally open contacts on the 24-vac relay.
- 11.2 Since power is not supplied to the actuator, it will spring return clockwise to the open damper position if not already there. When the actuator reaches the full clockwise position (full open damper) the internal auxiliary end switch closes (S1 to S3).
- 11.3 24-vac power will be supplied through the S1 – S3 contacts and the combustion air switch to the S8680 control.
- 11.4 The control will begin its pre-purge time period of approximately 30 seconds.
- 11.5 At the end of the pre-purge period, a trial for ignition will be attempted. On pilot ignited burners, the pilot pressure would be set here to achieve the best pilot performance. **Refer to Pilot Adjustment Procedure earlier in section 7.10** of this manual.
- 11.6 When the main gas valve is energized, after a proven pilot or during direct spark ignition on DSI burners, the 24-vac relay will also be energized.
- 11.7 One set of normally open relay contacts close which interlocks the high fire auxiliary end switch. Another set of relay contacts closes and completes the modulation circuit.
- 11.8 Modulation of the burner is now accomplished by the control signal. Depending on the setting of the Direction Control Switch located on the actuator (**Figure 15**), a low or high input signal can drive the actuator clockwise or counterclockwise (low fire or high fire).
- 11.9 An adjustable stop located on the actuator (**Figure 15**), is used to limit the high fire or low fire position. If the high fire damper position is changed due to a lower than maximum firing rate, the pilot should be re-checked at this new damper position.

### AMCX-24 BELIMO ACTUATOR

- 11.10 The AMCX actuator is available with control signal inputs of 2-10 vdc, 4-20 mA or 0-135 ohm. Therefore, refer to the specific wiring diagram supplied with the burner.
- 11.11 Upon a call for heat, the blower motor starts, closing the combustion air switch. Power is supplied to the 24-vac transformer which powers the AMCX actuator causing it to drive to the open damper position.
- 11.12 When the damper opens to the high fire position, the high fire end switch (purge switch) closes which provides power to the ignition control (S8670).
- 11.13 The control will begin its pre-purge time period of approximately 30 seconds.
- 11.14 At the end of the pre-purge period, a trial for ignition will be attempted. On pilot ignited burners, the pilot pressure would be set here to achieve the best pilot performance. **Refer to Pilot Adjustment Procedure earlier in section 7.10 of this manual.**

- 11.15 When the main gas valve is energized, after a proven pilot or during direct spark ignition on DSI burners, the 24-vac relay will also be energized.
- 11.16 One set of normally open relay contacts close which interlocks the high fire auxiliary end switch. Another set of relay contacts closes and completes the modulation circuit.
- 11.17 Modulation of the burner is now accomplished by the control signal. Depending on the setting of the Direction Control Switch located on the actuator (**Figure 15**), a low or high input signal can drive the actuator clockwise or counterclockwise (low fire or high fire).
- 11.18 An adjustable stop located on the actuator (**Figure 15**), is used to limit the high fire or low fire position. If the high fire damper position is changed due to a lower than maximum firing rate, the pilot should be rechecked at this new damper position.

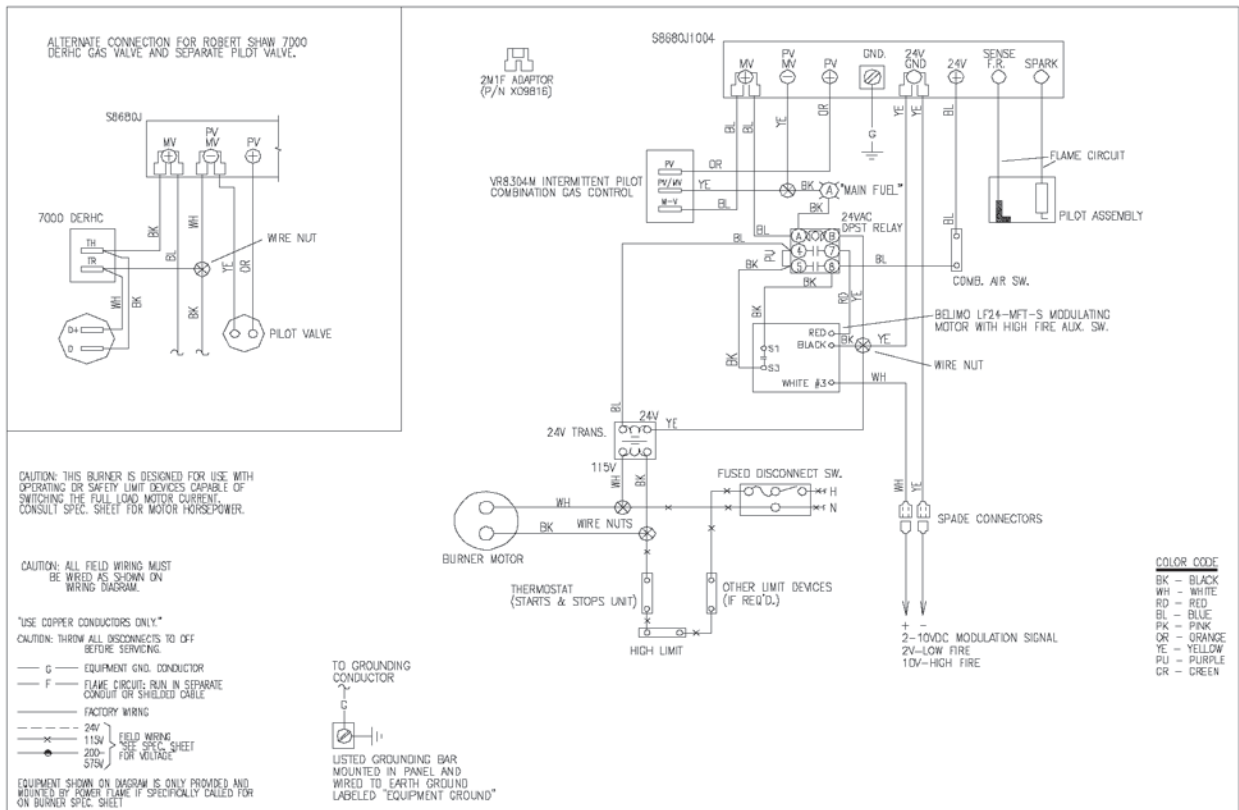
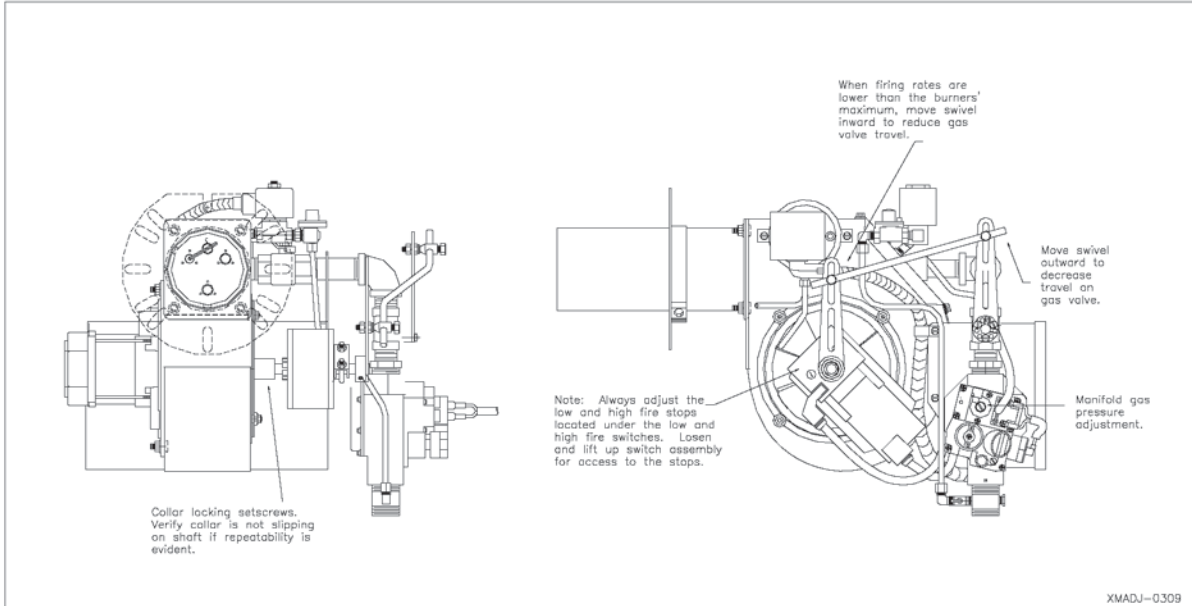
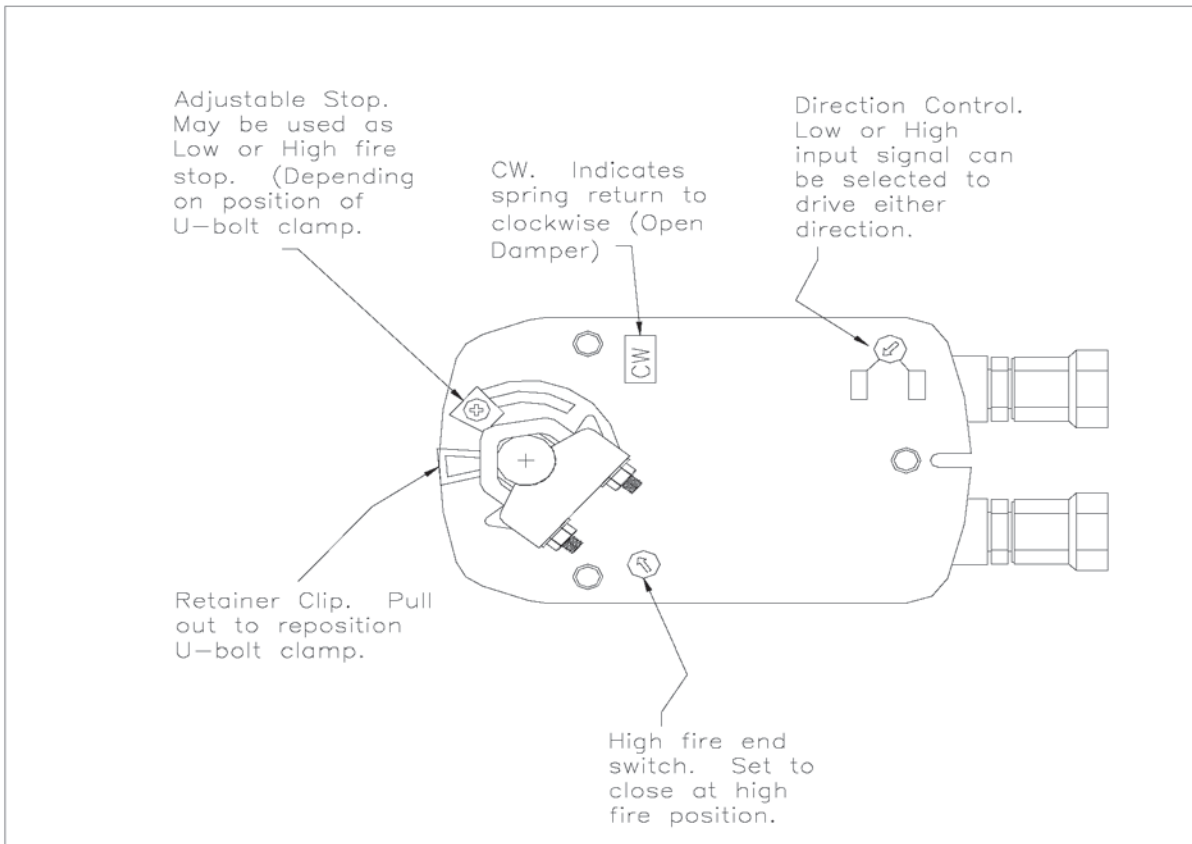

Figure 13: Typical Wiring Diagram For X4M with LF-24 Actuator



**Figure 14: General Arrangement Diagram for X4M (AMCX-24)**



**Figure 15: Belimo LF24-SR-S Actuator**

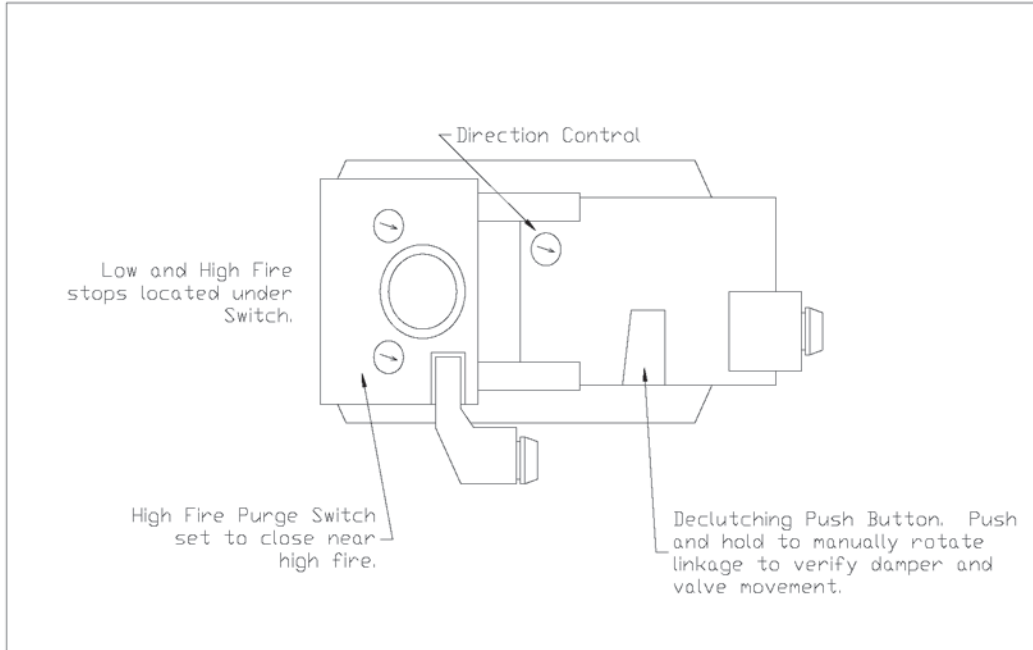

Figure 16: Belimo AMCX-24 Actuator

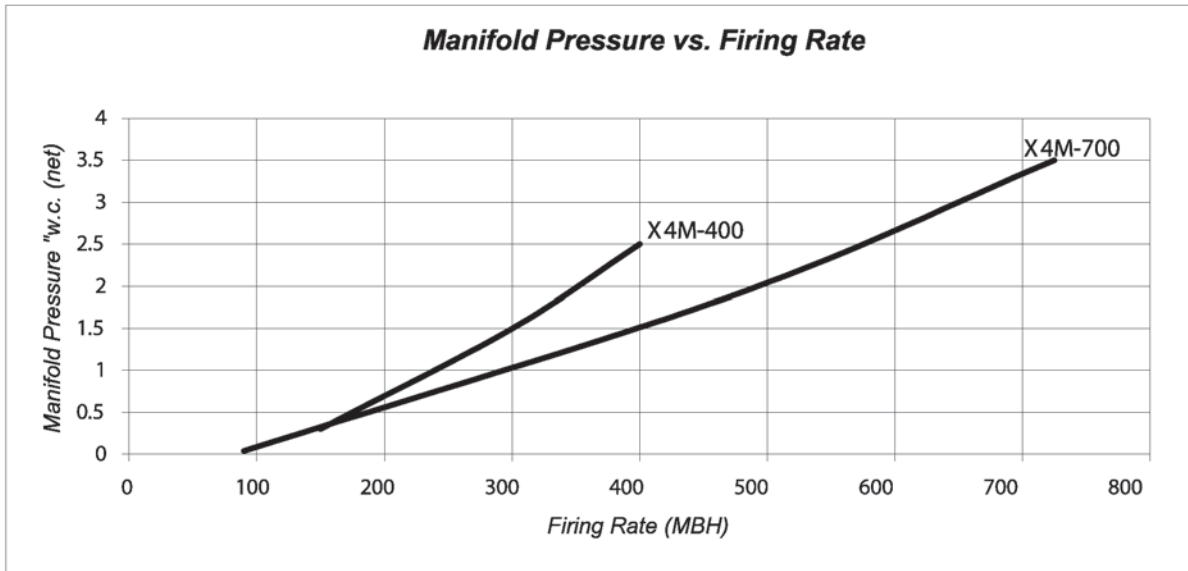

Figure 17: X4M Firing Rate vs Manifold Pressure

11.19 The manifold pressures shown are the gas pressures taken at the 1" tee and represent a zero furnace pressure (net manifold pressure). Therefore, the actual furnace pressure must be subtracted from these pressures to obtain the correct firing rate. Example: While firing an X4M-400, the Manifold pressure is 3.0" w.c. The furnace pressure from the manometer reads 0.5" w.c. Therefore, 3" - 0.5" = 2.5"w.c. **The chart in Figure 17** shows 2.5"w.c. net manifold pressure is equal to 400,000 BTUH.

## 12. X4M HTD (High Turn Down)

- 12.1 The main difference between the X4M and X4M-HTD is the use of the 1/3 hp ODP motor on the HTD model to prevent air infiltration at the low end of the firing rate.
- 12.2 Each of the HTD model's maximum firing rate may be reduced by either lowering the combination valve regulator outlet pressure or by placing an orifice in the orifice tee (see Fig. 4, page 8 for the orifice location). It is not necessary to use a main gas orifice except when it is desired to further reduce the burner's maximum firing rate. See Table 5 for orifice sizes and approximate pressures.
- 12.3 When no orifice is used, refer to the pressure/rate on Figure 17, page 22 for the approximate manifold pressure (taken on orifice tee) for a given firing rate.

<b>Burner Model</b>	<b>Firing Rate Min/Max (BTUH)</b>	<b>Orifice Tee Pressure (no orifice)</b>	<b>Damper Opening @ High Fire</b>
X4M-400-HTD	35,000/400,000	See page 22	Wide Open
X4M-400-HTD	35,000/350,000		2" (approximate)
X4M-400-HTD	35,000/250,000		1-1/8" (approximate)
X4M-700-HTD	65,000/725,000		Wide Open

**Table 6: Firing Rate and Damper Opening for X4M-HTD**

- 12.4 The setting up of the X4M-XXX-HTD is identical to that of the standard X4M burner. Follow the same procedures as listed in this I&O manual.
- 12.5 When properly set up, the burner will operate between 6% and 11% excess O<sub>2</sub> at the low fire rate while maintaining less than the maximum allowable air free CO of 400 ppm.
- 12.6 As with the standard modulating X4M burner, the HTD version is designed to light off at the high fire (open damper) position. At this position, the pilot performance is improved and a full open damper air purge is accomplished.
- 12.7 When the burner is set up to fire at a reduced maximum firing rate and the damper opening is set accordingly, the high fire switch located on the Belimo actuator must be set to close at this position. Power will not be provided to the flame control module until the switch closes.
- 12.8 For specific wiring connections, refer to the wiring diagram provided with each burner as listed in the burner's As Built Sheet.

NOTES: \_\_\_\_\_

\_\_\_\_\_

\_\_\_\_\_

\_\_\_\_\_

\_\_\_\_\_

\_\_\_\_\_

\_\_\_\_\_

\_\_\_\_\_

\_\_\_\_\_

\_\_\_\_\_

\_\_\_\_\_

\_\_\_\_\_

\_\_\_\_\_

\_\_\_\_\_

\_\_\_\_\_

\_\_\_\_\_

\_\_\_\_\_

\_\_\_\_\_

\_\_\_\_\_

\_\_\_\_\_

\_\_\_\_\_

\_\_\_\_\_

\_\_\_\_\_

\_\_\_\_\_

\_\_\_\_\_

\_\_\_\_\_



### 13. OWNER OPERATING INSTRUCTIONS FOR YOUR SAFETY

If you smell gas:

- 1. Open windows
- 2. Do not touch electrical switches
- 3. Extinguish any open flame
- 4. Call your gas supplier immediately

Do not store or use gasoline or other flammable liquids and vapors in the vicinity of this or any other appliance.

#### IMPORTANT PRECAUTIONS

- 1. Never attempt to light burner with paper or other materials.
- 2. Never experiment with the burner.
- 3. Never change the fuel or air adjustments without consulting with the burner service company.
- 4. Never attempt to light the burner if combustion chamber contains any unburned fuel or gases.
- 5. Never throw waste paper, rags, garbage or other waste materials into the combustion chamber.
- 6. Never wash out heating equipment room without first covering the burner with waterproof material.

#### WARNING

Improper installation, adjustment, alteration, service or maintenance can cause injury or property damage. Refer to the burner manual. For assistance or additional information consult a qualified installer, service agency or the gas supplier.

#### Preparation for Start Up – All Fuels

- 1. Ensure that the system is in working order. If heat exchanger is a boiler, ensure that proper water level is available.
- 2. Set the burner control panel switch to the OFF position.
- 3. Combination Gas Burner – set the fuel selector switch to the fuel to be burned.
- 4. Turn the thermostat or operating control down to its lowest setting.
- 5. Check fuses and replace as necessary.
- 6. Depress the flame safeguard programming control reset button.

#### Start Up

- 1. Manually open and close the main gas shut off cock, leak test cock and pilot cock to determine that they operate freely. Open all three cocks. (Reset low gas pressure switch if supplied).
- 2. Set the main power switch and burner panel control switch to the ON position. Wait 30 seconds and turn up thermostat or operating control to the desired setting.
- 3. The burner blower motor will start and after a suitable pre-purge period (this will vary with the type of flame safeguard control supplied – but will usually be a minimum of 30 seconds), the burner pilot will light, after which the main flame will be established.
- 4. If the system does not respond properly, contact your qualified burner service company.

#### EXTENDED SHUT DOWN

- 1. Place main power switch and burner control panel switch in the OFF position.
- 2. Close all gas valves.
- 3. Cover burner to protect it from dust and dampness.

#### MAINTENANCE

- 1. See Maintenance section in burner manual for suggestions on periodic maintenance and service.



Remove this page and post near burner.



\_\_\_\_\_  
Burner Service Company

\_\_\_\_\_  
Date of Installation

\_\_\_\_\_  
Address

\_\_\_\_\_  
Telephone



## Power Flame Incorporated Limited Warranty

Power Flame Incorporated, hereinafter called the Seller, of 2001 South 21<sup>st</sup> Street, Parsons, Kansas, hereby warrants its equipment manufactured by it and bearing its nameplate (hereinafter called Warranted Equipment) in the respects and exclusively for the benefit of those users, described herein. THIS LIMITED WARRANTY SHALL EXTEND SOLELY TO THOSE PERSONS WHO ARE OWNERS OF THE WARRANTED EQUIPMENT DURING THE WARRANTY PERIOD HEREINAFTER DEFINED AND WHO USE SUCH WARRANTED EQUIPMENT IN THE PROJECT AND FOR THE PURPOSES FOR WHICH SUCH WARRANTED EQUIPMENT WAS ACQUIRED FROM THE SELLER. The Seller warrants its equipment to be free from defects in the material and workmanship under normal use and service for fifteen (15) months from date of shipment. Burner blast tube is warranted a full five (5) years. EXCLUDED FROM ANY COVERAGE UNDER THIS WARRANTY ARE DEFECTS IN WARRANTED EQUIPMENT FROM DAMAGE IN SHIPMENT, FAULTY INSTALLATION, LACK OF PROPER MAINTENANCE, CLOGGED OR DAMAGED FILTERS, MISUSE OR NEGLIGENCE. If any person becomes entitled to a claim under this warranty, such person shall, as a condition precedent to securing warranty performance, return the Warranted Equipment to the Seller's plant, 2001 South 21<sup>st</sup> Street, Parsons, Kansas, transportation prepaid. If the Warranted Equipment thus returned is found by the Seller to be defective for a cause and within a time covered by this Warranty, such equipment shall be repaired or replaced without charge; and returned to its owner or job site at the Seller's cost for transportation and handling. If inspection of the Warranted Equipment discloses defects not covered by this Warranty, the Seller shall notify the owner. Said equipment, at the owner's option (to be determined thirty (30) days from the date of notification), may be repaired or replaced at the expense of the owner and Seller's regular charges shall apply. Owner shall assume the cost for transportation and handling.

Equipment, which is repaired or replaced, shall carry a warranty equal to the unexpired portion of the original warranty. The Seller will commence inspection of any Warranted Equipment returned to it for warranty claim within seven (7) working days after the arrival of such Warranty Equipment at Seller's plant, and shall complete any repairs required under this warranty within sixty (60) days after such arrival, unless Seller shall sooner notify said owner of reasonable cause for delay beyond control of Seller. Warranty obligations hereunder will be performed only between the hours of 9:00 a.m. and 4:00 p.m. Monday through Friday and excluding holidays. Any person believing himself entitled to warranty performance hereunder is required to notify the Quality Assurance or Service Department of Power Flame Incorporated, 2001 South 21<sup>st</sup> Street, Parsons, Kansas, prior to return of any Warranted Equipment for repair hereunder. IN ALL EVENTS, SELLER WILL NOT BE LIABLE FOR AND WILL NOT REIMBURSE ANY LABOR, MATERIAL, OR OTHER REPAIR CHARGES INCURRED BY ANYONE OTHER THAN SELLER ON ANY WARRANTY EQUIPMENT, UNLESS SUCH CHARGES HAVE BEEN SPECIFICALLY AUTHORIZED IN ADVANCE IN WRITING BY SELLER. ANY WARRANTY IMPLIED BY LAW WITH RESPECT TO THE MERCHANTABILITY OR FITNESS OF THE WARRANTED EQUIPMENT IS HEREBY LIMITED TO THE DURATION OF THE WARRANTY PERIOD HEREUNDER. THE SELLER WILL NOT IN ANY EVENT BE LIABLE FOR ANY INCIDENTAL OR CONSEQUENTIAL DAMAGES ATTRIBUTABLE TO THE WARRANTED EQUIPMENT.



2001 South 21<sup>st</sup> Street, Parsons, KS 67357  
Telephone: 620-421-0480 FAX: 620-421-0948  
Website: <http://www.powerflame.com>  
e-mail: [CSD@powerflame.com](mailto:CSD@powerflame.com)

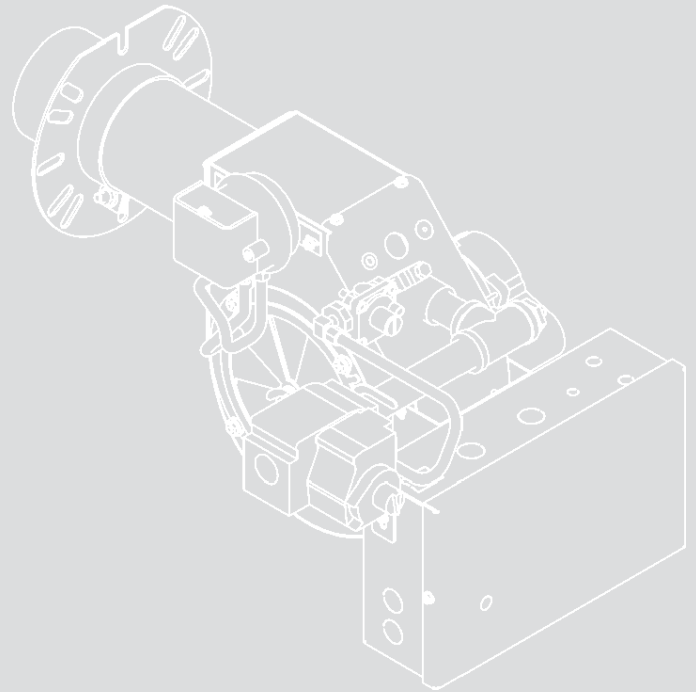
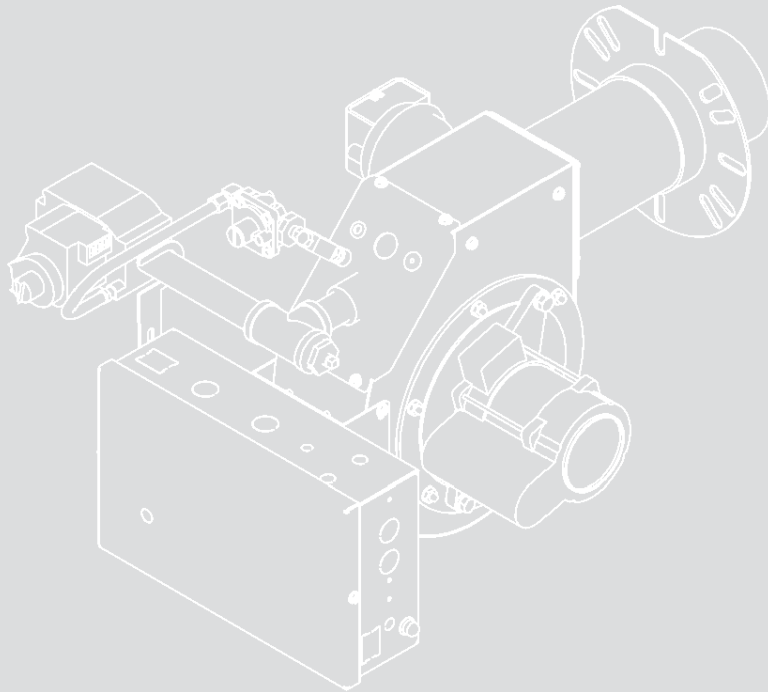
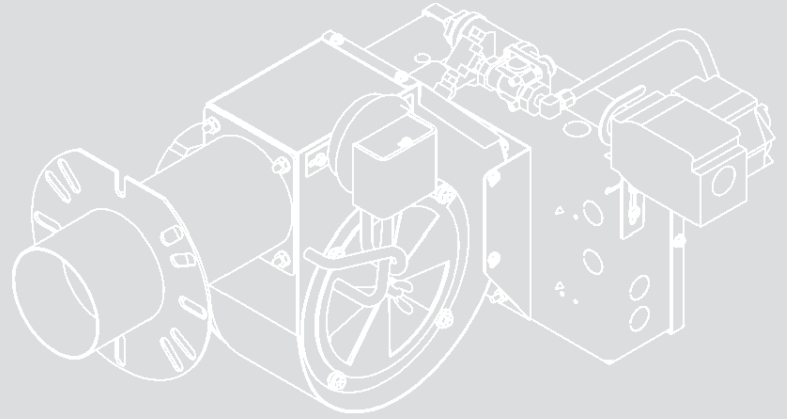
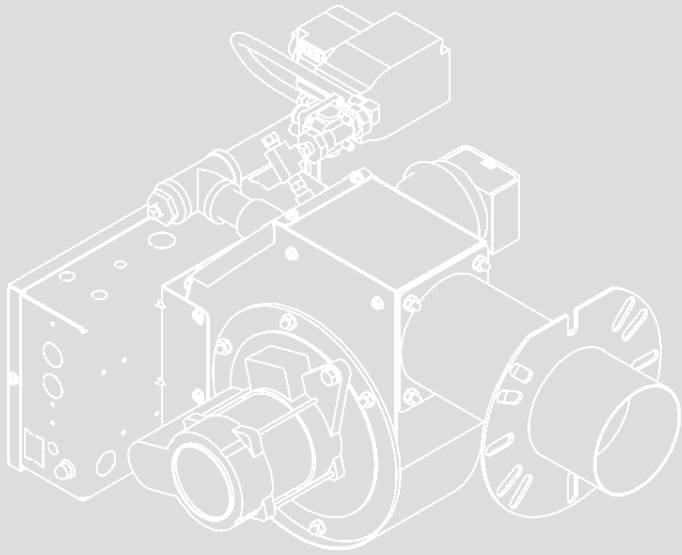

**Power Flame Incorporated**  
**2001 South 21<sup>st</sup> Street, Parsons, KS 67357**  
**Telephone: 620-421-0480 FAX: 620-421-0948**  
**Product Support: 620-820-8301**  
**Website: <http://www.powerflame.com>**  
**e-mail: [CSD@powerflame.com](mailto:CSD@powerflame.com)**